

# Our Community Newsletter

# BELMONT



## Town Meeting Update

Another Town Meeting/Election Day has passed and while our community had to brave a snowstorm, voters turned out to do their civic duty and cast their votes on important Town business.

Two new Selectmen were elected to the Board: Travis O’Hara for a three-year term and Sharon Ciampi for a one-year term. We look forward to working with them both and seeing what they can bring to Belmont. Claude (Sonny) Patten was also re-elected for a three-year term. This brings the Board of Selectmen to 5 members.



All but two of the warrant articles passed including the Operating Budget and articles related to our contracts with the Police Department, Fire Department and Public Works. We would like to thank the voters for their support.

## TAX BILLS



We anticipate tax bills will be mailed in mid-May this year and will be due the first week of July. Please remember that bills can be paid online.

Just a reminder that spring is here, and road crews will be picking up winter’s buried trash, clearing brush, picking up winter sand and salt left behind, as well as completing other roadside maintenance. Please be aware of their presence. You can also help by remembering “Please Do Not Litter” and as always please pickup after your dog.



## Property Assessments

Just a reminder that KRT Appraisal staff is in the community conducting assessments on 2022 Building Permits and other property changes. Staff have identification badges and carry letters from the Town explaining their purpose. Any questions regarding the process can be directed to Alicia Jipson, Town Administrator at 267-8300 Ext. 124.

## Come Join Our Team!

The amazing Town of Belmont has job openings. Come join our awesome team of great employees and see what great benefits we have to offer.

- Clerk in the Town Clerk/Tax Collector’s office
- Truck Driver Laborer
- Land Use Director
- 2 positions on the Fire Department supported by a SAFER grant
- Fire Chief
- Sargent Park Attendant (Seasonal/Part-time)

Please visit [www.belmontnh.gov](http://www.belmontnh.gov) for an application and job description.



## Town Administrator's News (con'td.)



We continue to stress the importance of the “Not everything is flushable”. **Please check out the “Do Not Flush!” list to protect your sewer and septic system.** A “Flushable” label does not mean it is SAFE for your septic system or the Town’s sewer. Please read the brochure we have included on the Town’s website at [www.belmontnh.gov](http://www.belmontnh.gov)

We need your help to ensure our sewers keep flowing.

Should you have any questions, please do not hesitate to contact the Town Administrator’s Office at 267-8300 ext. 124.

---

### Bulky Waste Disposal

**Please note that Casella will continue this program even after automated collection is in place.** On the 1st Wednesday of each month, Casella Waste will collect your bulky items curbside. Please note this is for Town of Belmont Residential Customers ONLY; service is not available to commercial property owners. Piles of debris, trash, yard waste or a single item too large for one person to collect WILL NOT BE ACCEPTED.

A request for pickup must be made in advance by calling Town Hall at 267-8300, Extension 118 or 124 only. You will be asked to list the items you want picked up, you will be



advised what the cost is, and you will need to drop off a check made payable to the Town of Belmont prior to the collection day. Please visit the Town’s website at [www.belmontnh.gov](http://www.belmontnh.gov) for the full details on the program and a price list.

### Calendar of Events/Meetings



Did you know that upcoming meeting schedules are available from our homepage at [belmontnh.gov](http://belmontnh.gov) by clicking the “Complete calendar of upcoming meetings and events” on the left-hand side of the screen?

Meeting agendas and minutes are posted in the Info Center > Meeting Agendas & Minutes.

Livestream and recorded meetings are available in the Info Center > Meeting Videos menu.



IT is the LAW! (RSA 466:31 II (c))

Our message to all dog owners is to remind you of the importance of picking up your dog’s waste from property that is not your own. The Town installed dog waste stations at three different locations. You can obtain a plastic bag to pick up the waste and deposit it in the numerous garbage cans located in the Village.



Just a reminder that the Town of Belmont is an active member of Lakes Region Public Access Television which can be seen locally on Breezeline Channels 24, 25, and 26. If you are a camera buff and you have an interest in producing a show to be shown on LRPA, please contact the station at 528-3070 to discuss your idea. LRPA has made significant strides to improve programming this past year and its presence in the Lakes Region. We urge you to check out their website at <http://lrpa.org>

## Town Clerk's Corner



Out of 4,300 registered voters thank you to the 531 brave souls who weathered the storm and came out to participate in our annual Town election that was held on Tuesday, March 14, 2023. The ballot results are posted on our website at [www.belmontnh.gov](http://www.belmontnh.gov). The Town Clerks would like to congratulate all of the new and re-elected board & committee members.

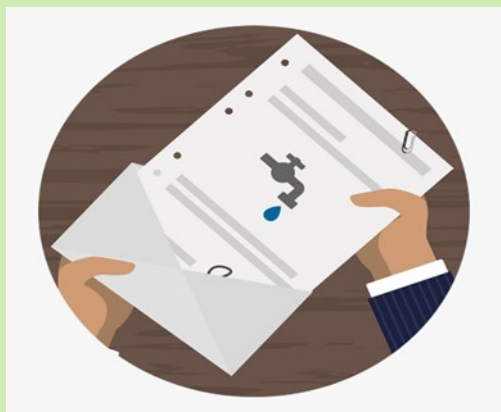

The first issue water and sewer bills are due April 6, 2023. The first issue utility bills cover the months of December, January, and February.

As a reminder, you may pay this in person, by mail, our front door drop box or online at [www.belmontnh.gov](http://www.belmontnh.gov). If you owe a balance from a previous bill, please give our office a call for the updated interest amount.

Delinquent notices were sent out in February to make residents aware of any unpaid balances from 2022. When mailing a payment on the 2022 items, we suggest that you give our office a call so we can help you get the correct payment amount due because of the interest.

April is the time of year that our office sends out Lien letters for residents that are not current on Taxes, Water or Sewer as of December 2022. The Lien process will occur as of May 2023.





## Town Clerk's Corner



Everyone can't wait for the warmer weather and to get beach passes!! Beach passes will be available in April. Please bring in your current registration so that we can put your plate number on your beach pass.

Just a reminder that renewals for dog licenses are due for the current year of 2023 by April 30th. You may renew them in person, mail, or online at [www.belmontnh.gov](http://www.belmontnh.gov), with your dog's current tag number from 2022. If you have a new puppy, we will need a copy of your current rabies vaccination paperwork. Senior dog owners that are 65+, your home will be able to license one dog for \$2.00. All altered dogs will be \$6.50 and non-altered dogs are \$9.00. If your home has 5 or more dogs, you will be charged a group rate of \$20.00.



Are you planning a spring wedding? Our office can help with the marriage license. A marriage license costs \$50.00 and is valid for 90 days. Both parties must be present to apply for the license and if either party has been previously married, they must bring in the official, sealed document showing how that marriage was dissolved. (For example: divorce decree, death certificate, etc.) It does take some time to process a marriage license application so we ask that couples come in no later than 3:30 PM. If you have any questions, please contact our office at 267-8300 xt. 2.





February 2023 Transactions and Revenue

	Transactions	Revenue Collected
Taxes		\$131,251.34
Boats	5	\$326.98
Dog Licenses	91	\$514.20
Motor Vehicles	813	\$148,580.86
Misc Fees	55	\$447.74
Water & Sewer		\$155,925.35
Totals	964	\$437,046.47



April 2023

## Police Department

*Captain Steve Akerstrom*



## Drug Take Back

On April 22nd from 10 am to 2 pm we will once again be participating in the DEA's National Drug Take back. During this time there will be someone here at the police department that will be available to take in unused prescription drugs.

The graphic features the text "DEA NATIONAL <sup>Rx</sup> TAKEBACK" in a stylized font. "DEA NATIONAL" is in blue, "Rx" is in red, and "TAKEBACK" is in white on a red and blue background. Below the text is a photograph of a tipped-over pill bottle with several red and blue capsules spilled out on a white surface.

**Turn in unneeded medication  
for safe disposal.**

**Saturday, April 22  
10 a.m.–2 p.m.**

**Keep them safe. Clean them out. Take them back.**

Visit [DEATakeBack.com](https://www.deatakeback.com) for a collection site near you.

## Dog Registrations

If you have a dog, it is almost that time of year when you need to register them. Dog registrations do expire on April 30<sup>th</sup>. This is a friendly reminder to get them registered as it can sometimes get overlooked with everyday life.

As always, if you have any questions for us, we can be reached at 603-267-8350.



# BFD Times

## BFD Welcomes Two To Our Crew!



BFD is excited to welcome Probationary Lieutenant Randy Danforth and Probationary Firefighter Ricky Raper. Lieutenant Randy Danforth will be overseeing Shift 2 and Firefighter Ricky Raper will be joining Shift 4! Both have completed their two weeks of working days and have officially started their shift rotation. This gives each of them a chance to work with all shifts and every member of the fulltime staff before going on their shift rotation. This also allows them to get acclimated before placing them on shift. Congratulations to both! Welcome to Belmont Fire!



### Posted Roads

All Roads in the Town of Belmont continue to be posted to a 6 Ton gross weight limit to protect the integrity of Town maintained infrastructure. Your Public Works Department understands the strain this puts on personal projects and business alike. We thank you for respecting the posted limits and assure you that they will be removed as soon as it is safe to conduct business as usual. For questions contact the Public Works Department at 603-528-2677.



### 6-Wheeled Dump Truck

Last week the Public Works Department took delivery of a new 2023 Western Star 4700 with underbody spreader. This truck replaces Truck 1, an International 6-Wheeled Dump which has been out of service since December of 2021. The Department's Capital Improvement Plan had called for its replacement a couple years prior but the economic climate along with pandemic uncertainties caused a delay. Spring 2022, voters approved the purchase and the truck was ordered. Supply chain issues for both the truck and body manufacturer left us with an undetermined delivery date. Although it is too late to place the truck in service this winter, the Department will be in a better position to combat whatever winter throws our way for the next one. The Team at the Public Works Department would like to take a moment to thank the taxpayers of Belmont, along with the Board of Selectmen and Budget Committee for their support. The entire Team at Your Public Works Department strives to set the standard for Maintenance in the area and the Town of Belmont has ensured the Department has the updated equipment to meet that goal!



Before you dig, remember to call DigSafe  
Not only is it safe, **IT'S THE LAW!**





## Parks & Recreation—Old Home Day Committee

We are busy planning the 2023 Old Home Day event and are looking for volunteers to join the Town of Belmont Old Home Day Committee. How many have been to our annual Old Home Day event and said “I wish we had this here” or “that would be cool”. This is your chance to be part of organizing the dayslong event. The committee will meet one time a month from January thru August. Meetings are held on the 3<sup>rd</sup> Saturday of the month. Whether you just have an idea or can commit to helping the day of the event, we would love to see you there!

# Belmont Old Home Day Committee



Belmont Parks & Recreation is looking for enthusiastic volunteers interested in becoming members of the Belmont Old Home Day committee.

Committee members will meet on the 3<sup>rd</sup> Saturday of each month to plan all aspects of our annual Belmont Old Home Day celebration.

Meeting:  
Saturday April 15<sup>th</sup> - 5:30pm  
Parks & Recreation office  
Belmont Mill - 2<sup>nd</sup> Floor

Meeting topics include:

- Committee Lead updates
- 10-Mile Road Race
- Daytime & Evening Activities
- Community Outreach
- Publicity Campaign

Interested residents are encouraged to attend the meeting and become part of planning what is one of the town's most popular annual events!

If you are unable to attend in person, but would like to contribute your ideas or volunteer for the day's activities, please contact Danielle St.Onge at [Recreation@Belmontnh.gov](mailto:Recreation@Belmontnh.gov) or call 603-267-1865

April 2023

EARTH DAY CLEANUP

**TOWN OF BELMONT**  
**EARTH**  
**DAY**  
**CLEAN UP**



**SATURDAY - APRIL 22, 2023**

**12:00PM**

**SARGENT PARK**

**COME JOIN US AS WE CLEAN UP OUR BEAUTIFUL PARK & VILLAGE AREA!**

**GARBAGE BAGS AND GLOVES WILL BE PROVIDED!**

**RAIN DATE - SUNDAY - APRIL 23, 2023**





# Belmont Old Home Day

August 12th, 2023

"Picture This"

**Come celebrate our picture perfect town of Belmont, NH for our annual Old Home Day. This years theme is sure to bring families, friends & community members together to create memories for a lifetime.**

**Live Bands • Parade • Family Games & Activities •  
Food Trucks & vendors • School & Community  
organizations • Raffles • Craft & Apparel vendors •  
Local Artists • Fireworks**

**For more information, vendor forms, parade forms, publicity opportunities or to volunteer for the days events, please visit [Belmonthnh.gov](http://Belmonthnh.gov) or email [events@belmonthnh.gov](mailto:events@belmonthnh.gov)**

**Applications, forms and more information about Old Home Day can be found on the Town of Belmont website at: [belmonthnh.gov](http://belmonthnh.gov) by clicking on the [Events > Old Home Day link](#) or clicking to [Departments > Parks & Recreation](#).**

## Parks & Recreation—Summer Camp

Registration for the Belmont Summer Camp has started! Be sure to secure your camper's spot to join in on the summer fun. With daily activities, arts & crafts, and weekly trips to the beach and area attractions, it's a time your camper won't want to miss!

**REGISTRATION OPENS FEBRUARY 1ST, 2023**

# BELMONT PARKS & RECREATION SUMMER CAMP

**ACTIVITIES**  
SPORTS, CRAFTS,  
CONTESTS, FIELD  
TRIPS, BEACH  
DAYS, FREE  
PLAY  
AND MORE

**JULY 3–AUGUST 11**  
**OPEN TO AGES**  
**5 AND UP**

**RESIDENTS**  
**\$155**  
**NON-RESIDENTS**  
**\$175**

**SIBLING DISCOUNT AVAILABLE**

**FOR MORE INFORMATION CONTACT**  
**DANIELLE ST.ONGE (603) 267-1865**  
**OR**  
**EMAIL RECREATION@BELMONTNH.GOV**

# BELMONT RAIL TRAIL SIGN IS COMING!

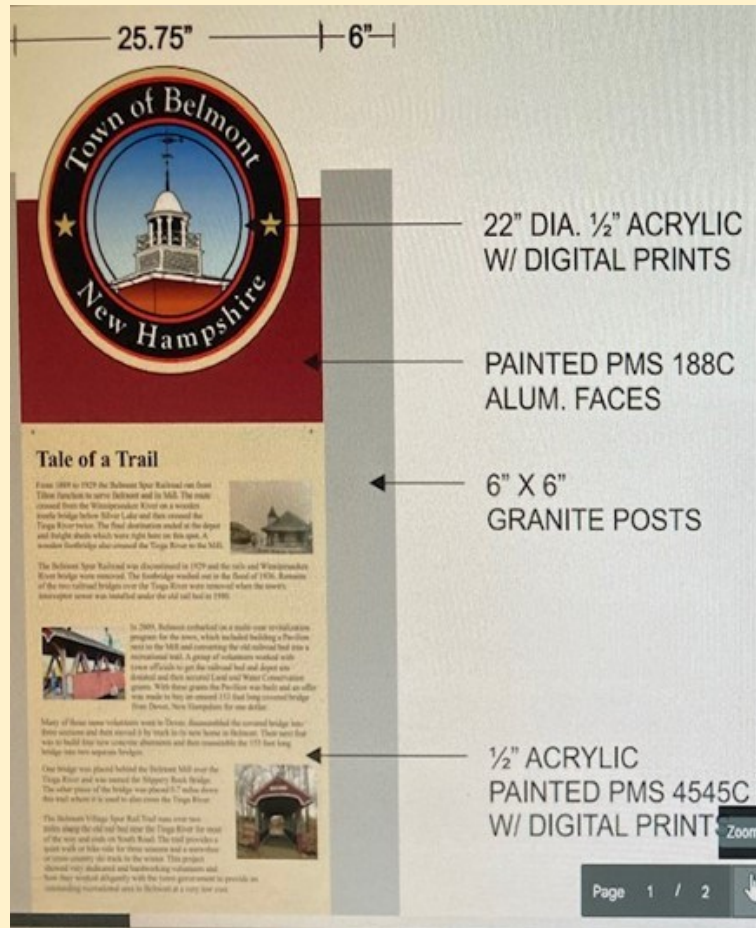

The Heritage Commission members have worked diligently to establish a new sign stating the history behind the Belmont Spur Rail Trail. It will soon be installed at the entrance of the trail. The design of the sign matches the ones located in the Village.

The new sign is titled “Tale of a Trail”. It also tells the story behind the purchase and maneuvering of the walking bridges. Most importantly the sign explains the significance of the history of the Belmont Railroad from the 1900s to its present day use as a very popular walking trail. Total installation of the posts and sign will be done this spring.

The Heritage Commission would like to thank the Sargent Fund Committee for their support with purchasing this historically information sign that will be enjoyed by the townspeople for many years to come.

**Heritage Commission**

**Vicki Donovan (Chair), Claire Bickford (Vice-Chair), Ben Rolfe (Secretary),  
Priscilla Annis, Jack Donovan, Jill Rolfe, Sonny Patten (Ex-officio)  
and Adam Ribeiro ( Student Representative—non-voting)**



# CONSERVATION COMMISSION

## WICKED BIG PUDDLES

Warm spring nights bring a chorus of wood frog and peeper mating songs. It is music to the ears and a sure sign that winter is over. Breeding wood frogs sound like a quacking chorus of ducks. And who can miss the sharp, piercing, bird-like sound of the tiny tree frog, the spring peeper? Here in Belmont, we might take this woodland orchestra for granted. But, did you know that this spring concert is only possible because of our “wicked big puddles” called vernal pools.



Vernal pools are temporary ponds that contain water for at least 2 months and do not have outlets (such as a river or a stream). Frozen ground helps retain water produced by rains or melting snow. The pools are often completely dry by summer or early fall. This annual drying keeps vernal pools free of fish. Certain species such as wood frogs, salamanders and fairy shrimp, unable to breed elsewhere, depend upon vernal pools as a fish free nursery for breeding. Otherwise, fish would feed on their vulnerable eggs and young.

In very early spring, frogs and salamanders emerge from hibernation and migrate to the vernal pool from which they developed. It may take the slow moving nocturnal salamander a few nights to reach the pool. They may have to cross roads and patches of snow to arrive at a pool still mostly covered with ice. Salamanders follow specific paths to their vernal pools. If a road has been built between their over-wintering site and the pool, many will die in the migration as they cross the road. Once mating and egg laying occur, the frogs and salamanders will return to the uplands where they spend most of their lives (up to 20 years!) in burrows and under logs. ***A fist-sized wood frog egg mass, on the right, along with egg masses of spotted salamander (upper) and Jefferson salamander (left).***



Vernal pools are an often-overlooked ecosystem. Because they dry up, they are not always appreciated as an important wetland type. Vernal pools are not only essential to breeding salamanders and frogs but they also influence the entire forest ecosystem by supplying food and water resources for many other organisms such as turtles, ducks, deer and other mammals, red spotted newt, dragonflies, and many other species.

# CONSERVATION COMMISSION

Some development practices can destroy vernal pools and their adjacent habitat. Disturbing the tree canopy allows for quicker warming of the water, hastens evaporation and shortens the time for young amphibians to develop.



Destruction of a pool and its uplands exterminates all the future generation of animals that depend upon the pool. Forestry, construction and agricultural projects could be modified to help protect these vital ecosystems. Some States “certify” vernal pools through the Wetlands Protection Act, which provides protective guidelines for development.

*Female wood frogs laden with eggs heading to a vernal pool.*

The spotted salamander, *Ambystoma maculatum*, is a fossorial salamander seldom seen because of its secretive nature and nocturnal feeding habits.



Exploring vernal pools is fun and educational. They are thriving little communities that play a vital role in the forest ecosystem. Visit Belmont’s conserved properties (listed on the Town Website) to discover vernal pools. (Hint...The Village Spur trail is a good spot)! This spring when you hear the joyful sound of peepers and wood frogs, remember that their future depends on us.

To learn more go to [www.vernalpool.org](http://www.vernalpool.org)

*(Resource and photos by the Vernal Pool Association)*

***Who are your Conservation Commission Members?***

Denise Naiva, Chair - Ed Stephenson, Vice Chair

Ruth Mooney, Ex Officio - Jane Jordan

Pauline Tessier - Susan Irving - Georgina Lambert

Richard Moreau, Alternate - Deborah Woodcock, Alternate

Student Members Emilie DeFrancesco & William Riley

**Conservation Commission**

**Upcoming meeting:**

**WEDNESDAY**

**April 5, 2023**

**6:00 PM**

**Meetings are held at the  
Belmont Mill.**



### Think Twice Before Buying Easter Chicks

With Easter coming soon, you'll be seeing ads for Easter chicks. Aww...aren't they cute? However, the Town considers chickens, even the cute little chicks, to be agricultural animals and NOT pets.

Chickens, ducks, guinea hens, pigs, goats, and other agricultural animals are only permitted by Special Exception from the Zoning Board of Adjustment for lots less than three acres in all zoning districts. On lots larger than three acres, agricultural animals are a permitted use in the Residential Multi (RM); Residential Single (RS) and Rural (R) Zones. On lots larger than three acres in the Commercial (C); Industrial (I) and Village (V) agricultural animals are only permitted by Special Exception from the Zoning Board of Adjustment.

If you're not sure what zoning district you live in, check your tax card on the Town website at [belmontnh.gov](http://belmontnh.gov) or call the Land Use office at (603) 267-8300 ext. 3 to find out.



April  
2023

**In this issue >>>**

*Upcoming Meetings:*

- ARC – 4/20/2023 (if needed)*
- Planning Board – 4/24/2023*
- Zoning Board – 4/26/2023*



**A Monthly Insight into the happenings in Belmont Land Use**

**March Meetings >>>**

***Your Land Use Staff***

***Karen Santoro***  
*Interim Planner/ Land Use Technician*

***Susan Austin***  
*Administrative Assistant*

***Elizabeth Stewart***  
*Land Use Clerk*

For additional Land Use Information:

Visit [www.belmontnh.gov](http://www.belmontnh.gov)  
Contact

[luoffice@belmontnh.gov](mailto:luoffice@belmontnh.gov)  
Call 603-267-8300 x 3



**Application Review Committee (March 16, 2023)**

**JB Thompson Realty Ventures:** Review of application for a 7-lot subdivision located on Laconia Road. Property is in the Industrial Zone. Tax Lot 241-013-000-000, #02-23R.

**REM Central LLC:** Review of application for a Minor Site Plan to modify the existing site plan to allow occupation by Dunkin located at 223 Daniel Webster Highway. Property is located in the Commercial District. Tax Lot 101-028-000-000, #03-23R.

**Lakeview at Belmont:** Review of application for a Subdivision and Site Plan to build a Golf Course, clubhouse, three single family residential lots and nine condominium units. Property is located at 89 Ladd Hill Road in the Rural District. Tax Lots 201-066-000-000 and 201-067-000-000. #04-23R

**Field Lane at Belmont NH LLC:** Review of application for a Site Plan to build a self-storage facility with three buildings. Property is located on Field Lane in the Industrial Zone, Tax Lot 245-007-000-000. #05-23R

**Planning Board (March 27, 2023)**

**Plan Submission Meeting and Public Hearing - Route 106 Realty Trust:** Request for a 1-year site plan approval extension for a self-storage facility. Property is located on Old State Road, Tax lot 201-003-000-000 in the "C" Zone. PB Case # 0323-P.

**Plan Submission Meeting and Public Hearing – Gilmanton Sand and Gravel:** Request for Five-year compliance hearing for earth excavation permit

***continued...***

**Zoning Board of Adjustment ( Meeting March 22, 2023)**

**Abutters’ Hearing – Timothy Morgan:** (Continued from 2/2/2023) Request for a variance of Article 5 Table 2 of the Zoning Ordinance to construct a single family home closer (20’) to an unrelated structure on the same lot than allowed (30’) Property is located at 28 Wakeman Road in the “RS” Zone, Tax Lot 111-024-000-000. ZBA# 0223Z. - Approved

**Abutters’ Hearing - Kimberly Haney:** Request for a Special Exception to Article 5 Table 1 of the Zoning Ordinance to allow agricultural animals (horses) on a property less than 3 acres. Property is located at 191 Dutile Road in the “RS” Zone, Tax Lot 217-027-000-000. ZBA# 0623Z.—Withdrawn by applicant

>>> **Next Regular Meeting: April 26, 2023 6:00PM**

**2023 Proposed Zoning Amendments: Passed at March 14, 2023 Town Meeting**

1. Add housekeeping clause to Article 1.
2. Add new definition to Article 15 and use to Article 5, Table 1 for Solar.
3. Change definition for Storage Facilities in Article 15 and add Shipping Containers as a use to Article 5, Table 1.
4. Change definition of Day Care Facilities in Article 15 to include all individuals.
5. Change definition of Frontage in Article 15 to clarify that Right-of-Ways do not provide frontage unless they meet the requirements of RSA 674:41.

**The full text amendments are available for review in the Land Use Office**

# Looking for Board members!

Visit the Town’s website:  
[www.belmontnh.gov](http://www.belmontnh.gov)  
to read about the various Boards and  
submit and application.

**Planning Board**

- 7 regular members, 3 alternates
- **1 vacancy**

**Zoning Board**

- 5 regular members, 5 alternates
- **5 vacancies**

**Conservation (no current vacancies)**

- 7 regular members, 3 alternates, 2 student members



# Building Department News from the Building Official



Spring has sprung, and it just might be time to replace those old inefficient windows that have fogged up inside the panes, or perhaps parts of the window frame are starting to show their age (rot), or they just don't open properly like they used to.

Here are some things you should look for before you purchase windows. Ask your contractor or installer what kind of energy efficient features the windows come with.

- Should you purchase vinyl or wood?
- Should they be double-pane, triple-pane or low-E glass?
- What does it mean to have gas-filled panes?
- What is the U-Factor of the windows? (U-Factor generally refers to the energy efficiency of the complete window assembly. The lower the U-Factor, the better the window. Codes in our area require a U-Factor of 0.30 or lower.)
- Be sure to shop around and compare prices.



As always, before starting any building project, please give us a call and we will be happy to help you determine if a permit is required.

Please contact us at 603-267-8300 xt. 111 or email us at [codeenforcement@belmontnh.gov](mailto:codeenforcement@belmontnh.gov).

Thank you,

Mark Ekberg, Building Inspector

Coming next month:  
Roof Replacements

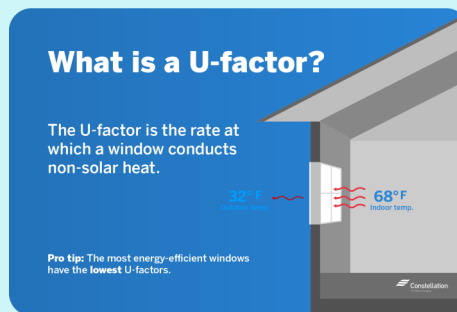
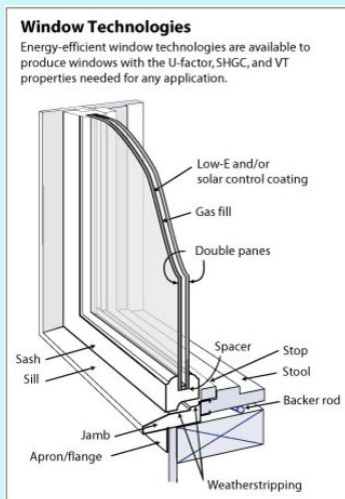

 National Fenestration Rating Council® <b>CERTIFIED</b>	
ENERGY PERFORMANCE RATINGS	
U-Factor (U.S./I-P)	Solar Heat Gain Coefficient
<b>0.30</b>	<b>0.30</b>
ADDITIONAL PERFORMANCE RATINGS	
Visible Transmittance	Air Leakage (U.S./I-P)
<b>0.51</b>	<b>0.2</b>
<small>Manufacturer stipulates that these ratings conform to applicable NFRC procedures for determining whole product performance. NFRC ratings are determined for a fixed set of environmental conditions and a specific product size. NFRC does not recommend any product and does not warrant the suitability of any product for any specific use. Consult manufacturer's literature for other product performance information. <a href="http://www.nfrc.org">www.nfrc.org</a></small>	



# Belmont Public Library

April 2023

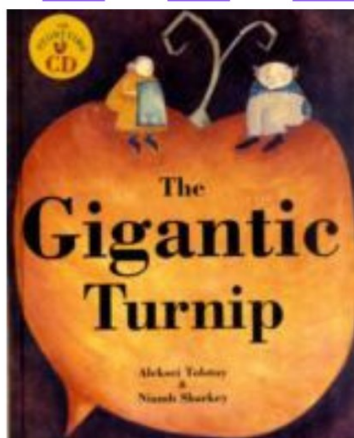

**Storywalk© starts April 17**

**TECH HELP VOLUNTEER DROP-IN**  
Fridays in April at 10am

**SPRING FLING VACATION WEEK**

Different themes every day!

4/24: MOVIE MANIA MONDAY  
12:30PM BOOK TO MOVIE LUNCH

4/25: TIME WARP TUESDAY  
11 AM LEGO CHALLENGE

4/26: WESTERN WEDNESDAY  
1PM BOARD GAME FUN

4/27: TEAM THURSDAY  
ALL DAY DROP-IN SCAVENGER HUNT

4/28: FLOWER POWER FRIDAY

Monday Friday 10am-5pm

Tuesday Wednesday Thursday 10am-6pm

Saturday 9am-1pm

belmontpubliclibrary.org (603)267-8331

**Musical Munchkins**

Mondays 10am

**Storytots**

Wednesdays 10am

**Cursive Club**

Wednesday, 4/5 & 4/19, 430pm

**Family Storytime**

Saturday April 15 11am

Children/Family

**Teen Tuesday 3pm**

4/4 Rhyme and Reason

4/11 Innovation Station

4/18 Young Ink

4/25 Crafternoon

**GSF Book Club ages 10-14**

Thursday, April 6 3pm

**I.F. Book Club ages 14 - 18**

Thursday, April 20 3pm

**Teen Advisory Board**

Thursday, April 27 3pm

**Film Fridays 3pm \*no film 4/14**

Twens/Teens

**Watercolor Workshop**

Mondays 2pm

**Fiber Arts Group**

Wednesdays 10am

**Tech Help Volunteer Drop-In**

Fridays 10am

**Tea & Tales Book Club**

Thursday April 13 5pm

**Friday Fiction Book Group**

Friday April 21 10:30am

Adults

146 Main Street ~ [circulation@belmontpubliclibrary.org](mailto:circulation@belmontpubliclibrary.org)

Monday & Friday 10-5; Tuesday Wednesday Thursday 10-6; Saturday 9-1

# GET THE COVID-19 BOOSTER TODAY!

Getting the booster helps keep you protected from serious illness, especially if you are over 50 or have health conditions like diabetes, heart disease or obesity that put you at higher risk.



## ONLY FOR A LIMITED TIME THE BOOSTER WILL COME TO YOU

### Schedule a Free:

- In-home visit for homebound residents
- Vaccination clinic for your organization or business

### Schedule Now!

Call **603-826-6500**  
or visit **VACCINES.NH.GOV**

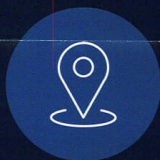

## ANYTIME FIND VACCINE RESOURCES NEAR YOU AT **VACCINES.NH.GOV**

# HAVE COVID-19 SYMPTOMS?

### Find Out About Treatment

- Talk to a health professional right away about treatment options
- Treatment is most effective when taken early and may reduce severity of COVID-19 if you are over 50 or have health conditions that put you at higher risk
- Ask about getting medication sent to your home or pharmacy

ONLY FOR A LIMITED TIME  
FREE TELEHEALTH APPOINTMENT  
CALL 7 DAYS A WEEK **800-816-5803**

ANYTIME  
FIND TREATMENT RESOURCES AT  
**COVID19.NH.GOV**



# General Assistance

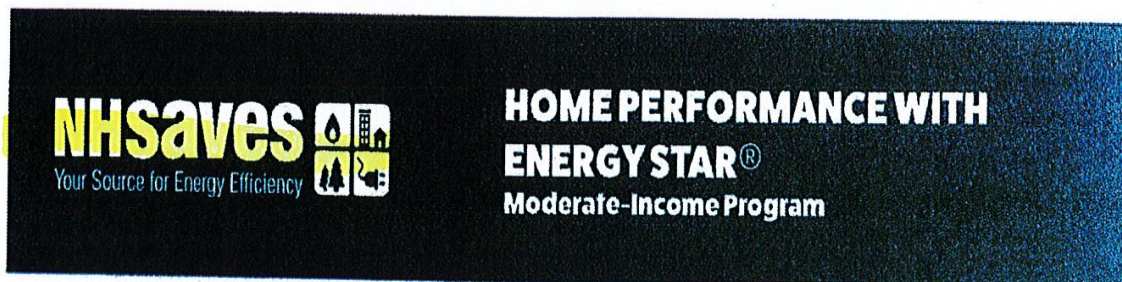

The Home Performance with ENERGY STAR - Moderate-Income (HPwES-MI) program is open to qualifying customers of Eversource, Liberty Utilities, Unitil, and NH Electric Cooperative. The HPwES-MI looks to support those NH residents that are over income for Home Energy Assistance (income eligible weatherization program) yet may struggle to cover the customer co-pays in our market rate Home Performance program. HPwES-MI offers higher incentives on weatherization measures and 0% finance options to help cover the customer co-pay.

The program rebate structure is as follows:

Measure Type	Incentive Level	Customer Co-Pay
Air Conditioning	80%	20%
Air Sealing	100%	0%
Appliance Timers	100%	0%
Door Replacements	80%	20%
Duct Sealing	80%	20%
Health & Safety	80%	20%
Heating System Clean & Tune	80%	20%
Heating System Replacements	80%	20%
Insulation	80%	20%
LED Bulbs	100%	0%
LED Fixtures	100%	0%
Low Flows	100%	0%
Pipe Insulation	80%	20%
Refrigerators/Freezers	100%	0%
Tank Wrap	80%	20%
Thermostats	100%	0%
Water Heater Setback	80%	20%
Window Replacements	80%	20%

**Program Requirements:**

- Income eligibility qualified by the Community Action Agency
- Open to customers who do not qualify for fuel assistance (over income for fuel assistance) but fall within the 80% state median income or 300% federal policy guidelines

**For more information, please contact Margaux Levesque with Eversource:**

**Margaux.levesque@eversource.com or 603-490-3506**



## Children's Auction — Press Release

### Greater Lakes Region Children's Auction Awards \$525,000 to 60 Nonprofits

LACONIA—The Greater Lakes Region Children's Auction (GLRCA) last week distributed \$525,000 in grants to 60 area nonprofit organizations at a luncheon event at the Huot Career and Technical Center that also included a workshop on digital marketing.



The 60 nonprofit leaders gathered their checks during the meet-and-greet event that also offered lunch prepared by students at the center and the half-hour marketing presentation.

Corina Locke, the creative director of SnapRoot Creative Digital Marketing, an agency that collaborates with the Auction, offered the talk on how nonprofits can use an online software graphics program called Canva to enhance the posting they are doing on social platforms like Facebook.

"We were glad to see everyone enjoying their meal and feeling grateful not only for their grant but for the chance to network with other nonprofit leaders and to learn from Corina," said Jaimie Sousa, chair of the Auction board. "It was a great opportunity to get everyone together."

Grants will be used by the local nonprofit organizations to fund wide-ranging programs that support local children and families in need. These programs address needs that are vital to the well-being of children in our communities, including food and housing insecurity and related emergency assistance; afterschool programs, recreation, education and the arts; childcare and related family resources; and healthcare, including victim outreach and support and preventative health and wellness training.

The Auction had \$686,398 in requests in 2022 from 65 nonprofits and awarded \$525,000 to 60 agencies. For specific distribution information, visit <https://www.childrensauction.com/whereourmoneygoes>.



Sousa is pleased with the 2022 Auction results. "In 2020 and 2021, while still impressive, our fundraising was impacted by the financial pressures of the pandemic. I am beyond thrilled to see the Auction emerging stronger than ever with a new fundraising record set in 2022," she said. "These funds are significantly improving the lives of local children by ensuring their basic needs are met, and they have opportunities to thrive. There are so many people from the Lakes Region and beyond that made this possible, and we cannot thank you enough for your generous contributions."

Sousa also thanked the Auction's board's Distribution Committee, which reviews all the grant applications and makes recommendations on funding.

April 2023

## Children's Auction — Press Release (cont'd.)

"We are so lucky to have a group of truly dedicated community volunteers who carefully review every application to ensure that we are best meeting the requirements and wishes of the children in need in our local communities," said Cindy Hemeon-Plessner, chair of the Distribution Committee. "Because of the committees' strength with problem solving, analysis, empathy and community awareness, we are able to ensure all who donate, bid and volunteer that the funding is being spent wisely."

The next round of grant applications will be due by Oct 15.

For more information about the GLRCA application and funding process, visit [www.childrensauction.com/applyforfunding](http://www.childrensauction.com/applyforfunding).

In past 41 years, the Auction has distributed \$8 million to nonprofit organizations in the community. Learn more about the Auction at [www.childrensauction.org](http://www.childrensauction.org), or follow the Children's Auction on Facebook, Instagram, Twitter, or LinkedIn.

###

### **About the Greater Lakes Region Children's Auction:**

The Greater Lakes Region Children's Auction holds numerous fundraising events in central New Hampshire throughout the year, including a cornerstone event every December. Countless volunteers and donors have turned the Auction and its many fundraising events into a major annual campaign, incorporating the Community Challenge. In the 41 years that the community has come together for the Auction, an impressive \$8 million has been raised and awarded to local nonprofit organizations, all through volunteer efforts, community donations and corporate sponsorship. The Greater Lakes Region Charitable Fund for Children is a 501(c)(3) nonprofit organization that helps community organizations in the Central New Hampshire region. For more information about the Auction, the nonprofits it supports and how you can help, visit [ChildrensAuction.org](http://ChildrensAuction.org).





# Recycling Calendar

## — 2023 — CURBSIDE RECYCLING COLLECTION CALENDAR

 Recycling collection day

 Holiday

- **Trash** is collected weekly and **recycling** is collected every other week on your service day as indicated below.
- Your service will be delayed by one day during weeks in which a highlighted holiday occurs.





# ZERO-SORT<sup>®</sup> RECYCLING

TOSS ALL CLEAN & EMPTY RECYCLABLES INTO THIS CONTAINER

## CARDBOARD/PAPER



**Corrugated Cardboard**  
(Wavy center layer)



**Boxboard**  
(Dry-food boxes, egg cartons, & rolls)



**Junk Mail, Periodicals, & Office Paper**  
(Paper bags, envelopes, & catalogs)

## PLASTIC



**Plastic Bottles, Jugs, Tubs, & Lids**  
(Empty kitchen, laundry, & bath containers)

## METAL



**Aluminum & Steel Cans**  
(Foil & empty food & beverage cans)

## GLASS



**Glass Bottles & Jars**  
(Empty food & beverage bottles & jars)

### NOT ACCEPTED

Plastic bags, bagged recyclables, clothing/textiles, food waste/liquids, tanglers such as rope or hoses, scrap metal, batteries of any kind, electronics, wood, medical waste, hazardous materials, explosives, toys, hangers, shoes, wax/cups or plates, food bags or wrappers, plastic wrap or film, shrink wrap, tarps, diapers, human/pet or yard waste, tires or rubber, Styrofoam™, napkins, paper towels, tissues, plastic utensils, register tape, condiment packets, straws, stirrers, coffee pods, ceramics, or baking glass



For recycling tips and resources, visit [casella.com/recyclebetter](https://casella.com/recyclebetter) • 800-CASELLA

Do you know someone new to Town, or know someone in Town who would love to see our Newsletter?



Please email Colleen Akerman at:

[assessing@belmontnh.gov](mailto:assessing@belmontnh.gov) to get on our newsletter distribution list!

